

EXPLODED VIEW

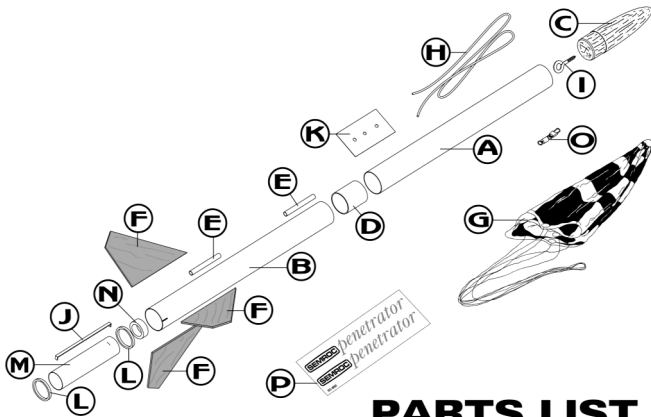

PARTS LIST

Item	Semroc Part #	Description
A	ST-8F90	Body Tube 9" Long
B	ST-8F90M	Body Tube 9" Long-Marked
C	BC-8F28	Balsa Nose Cone
D	HTC-8F	Tubing Coupler
E	LL-115	Launch Lugs (2)
F	FFS-MRK1	Laser-Cut Balsa Fins
G	CP-12RW	Chute Pak 12"
H	ECR-124	Shock cord 24"
I	SE-1	Screw Eye
J	EH-28	Engine Hook
K	SCM-8F	Shock Cord Mount
L	CR-78F	Centering Rings (2)
M	ST-730E	Engine Tube
N	TR-7	Thrust Ring
O	SV-12	Swivel Snap 1"
P	DFS-MRK1	Decal - Penetrator

JOIN THE NAR!

Sign up online at www.nar.org to join the premier model rocketry organization. Semroc fully supports the National Association of Rocketry and recognizes it as the sport's official voice. Check online at www.semroc.com/nar for promotions just for NAR members.





SEMROC
penetrator™

1967
with Repro

“Build a **GO** bird ~
not a show bird!”

**RUGGED
DESIGN**

**LASER-CUT
PLYWOOD
FINS**

XKIT™

**FLYING
MODEL
ROCKET
KIT**

**MADE IN THE
USA**

Instructions not included.
Available online.



Made in the U.S.A by Semroc Astronautics Corporation - Knightdale, N.C. 27545

Penetrator™ Kit No. XFS-MRK1

	Specifications	Engine	Approx. Altitude
Body Diameter	.921" (2.49 cm)	A8-3	225'
Length	21.0" (53.3 cm)	B6-4	600'
Wing Span	5.3" (13.5 cm)	C6-5	1250'
Net Weight	1.2 oz. (34.1 g)		

PARACHUTE RECOVERY

What is an xKit™?

A Semroc xKit™ is a kit designed for the expert modeler. It is a reproduction of the materials found in an early, historically significant model rocket kit. The parts are close enough that the original instructions can be used to construct the kit. Copies of original instructions of many early out-of-production kits are available online from several sources, the two best-known being Jimz and oldrocketplans.com. The xKit™ line is only available online and is intended for advanced builders that have experience with the instructions and designs from the early days of model rocketry.

About Flight Systems, Inc.

In early 1967, George Roos formed Flight Systems, Inc., "FSI", as a subsidiary of PyroChem Company, Inc. in Louisville, Colorado. For years he was the chief engine designer and manufacturer of innovative model rocket engines for FSI. Sometime between 1971 and 1974, FSI moved to Raytown, Missouri and while there Lonnie Reese served as president of the company until his death in 1984. FSI continued in business until around 1994.

Their kits were known for heavy-duty pre-cut plywood fins and hardwood nose cones. Early models used non-standard engine sizes of 21mm and 27mm with greater impulse than most of the existing model rocket engines. Their F7 and F100 engines achieved legendary status even though their performance was overrated and they tended to have more failures than the smaller engines available.

In 1990, 18mm engines and kits were introduced along with engine mount conversions for many of their kits. FSI was for many years one of the largest model rocket companies, but went out of business, leaving thousands of faithful fans hoping still today to see some of their innovative designs and engines again.

July 13, 2008

About the Penetrator™

The FSI Penetrator was released in 1967 as their first kit. It originally had plywood fins and a hardwood ogive nose cone. Designed to give altitudes of over 2500 feet with the long-burning D.915-6 engines, the Penetrator was a very high performer for the time. The Penetrator was introduced as Catalog #MRK-I and had an introductory price of \$2.00.

The Semroc Penetrator™ xKit™ is a very close approximation of the original kit. Laser-cut plywood fins are provided using the original patterns as models. The earliest versions had a streamer, but they were soon replaced with a parachute because of the weight. The original Penetrator was designed for 21mm engines, but an 18mm conversion was provided in later kits. This model has the 18mm engine mount since 21mm engines are no longer available commercially.

Plans are not provided in this kit but they are available online at

<http://www.oldrocketplans.com/fsi/fsiMRK-1/fsiMRK-1.htm>

thanks to the tireless efforts of Scott Hansen at Ye Olde Rocket Plans.

Construction Notes

1. After downloading the instructions, they should be read and understood before beginning construction. The FSI instructions are sometimes hard to follow, so patience is required.
2. Flameproof wadding mentioned in the instructions is NOT included. Fiberglass is not recommended in model rockets.
3. The 18mm engine mount should be assembled as shown in the drawing. Insert the engine hook in the pre-slotted tube. Glue the thrust ring in the top of the engine tube against the top of the engine hook. Slide the two centering rings over the tube and engine hook as shown. Apply glue fillets around all the joints, keeping glue off the outside edges of the rings. Apply a bead of glue inside the main body tube and glue the mount in place. Leave about 1/4" protruding from the end of the main body tube.

